

High Volume Tapping Tee (HVT)

OPERATING INSTRUCTIONS

1. Mounting surface must be clean and free of cuts and scratches.
2. Place top half of the saddle on the main. Place the bottom half of the saddle on the main with the holes lined up to insert the bolts. Insert all bolts and start the threads. Tighten two center bolts first using care to pull the saddle down evenly by tightening alternately front and back bolts, taking care not to rotate saddle on main. Do not move saddle after bolts are started. Tighten remaining bolts evenly until flanges of saddle come together.

COMPRESSION OUTLET INSTRUCTIONS

1. See other side for compression outlet assembly instructions.

TAPPING MAIN

1. Remove cap and o-ring, insert tapping tool (33-4363-00) into punch.
2. Screw punch clockwise until the stop on tapping tool contacts the top of the tee. (If possible, avoid pausing until tap is complete).
3. To allow flow through the service, rotate the punch counter-clockwise until the top of the punch is flush with the top of the tee. It is important that the punch does not protrude above the tee.
4. Inspect o-ring for debris and clean if necessary. You may apply silicone valve lube to the o-ring groove before replacing the o-ring in top of saddle. Install cap on HVT and screw cap down ¼ turn past hand tight.

DEAD END OUTLET ASSEMBLY INSTRUCTIONS

1. Stop flow prior to installing dead end outlet on live services. (See step # 2 under "TAPPING THE MAIN").
2. Remove existing outlet components.
3. Install dead end nut as shown below tighten dead end nut until it shoulders against outlet. **Do not over tighten.**

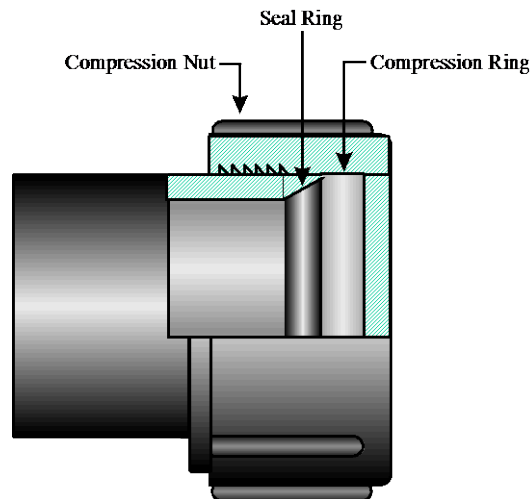

IMPORTANT

For use on:

Thermoplastic gas pipe meeting the requirements of ASTM D 2513

Pressure Rating: Designed to meet or exceed pressure rating of PE pipe per 49 CFR Part 192 and ASTM D 2513.

Operating Temperature: -20 to 140°F

ASSEMBLY INSTRUCTIONS FOR 1-1/4" IPS AND 2" IPS COMPRESSION OUTLETS

1. Clean pipe ends. The pipe ends should be undamaged and squarely cut. Deburr inside of pipe ends if necessary.
2. Inspect the pipe to ensure that there are no cuts or gouges located in the sealing area of the pipe.
3. Mark the maximum stab depth (see example for correct pipe size and corresponding stab depth) from the end of the pipe.

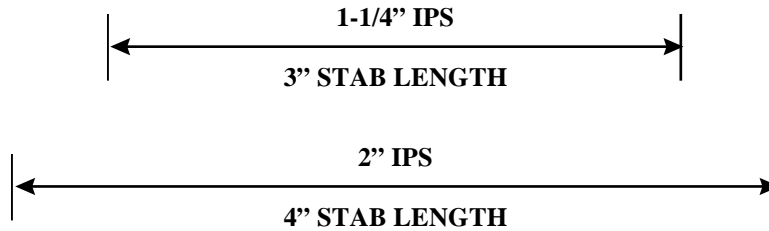

4. Remove the red cap plug and stiffener from end of outlet without removing the compression nut (discard the cap plug). Tap the stiffener into the pipe until the ID of the pipe rests on the knurl of the stiffener.
NOTE: If protective sleeve is required, slip it over pipe now, before making up outlet.
5. Stab the pipe into outlet up to (not past) the stab mark. (When stabbing the pipe, the compression nut should be loosened to the point that at least three to five threads are showing). See figure 1.

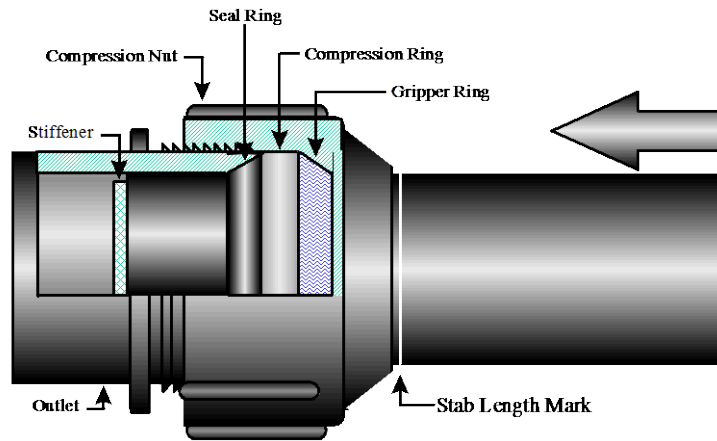

Figure 1

6. Tighten the compression nut until it shoulders against the body of the outlet. **Do Not Over Tighten.** If you cannot see the stab mark or the end of the compression nut is not within the distances listed below, reassemble the fitting. See figure 2.
7. Maximum distance from the end of the compression nut to the stab marks are shown below:

Pipe Size (Inches)	Maximum Distance (Inches)
1-1/4	5/8
2	1

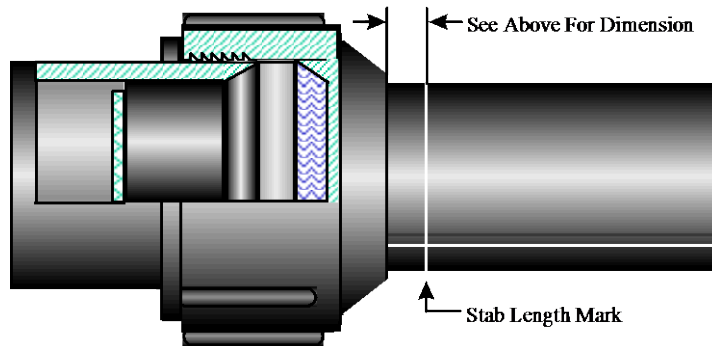

Figure 2

NOTE: It is advisable to limit shear at main connections. In this regard, your company's policies should be followed. For further information, reference; ASTM D 2774 Standard Practice for Underground Installation of Thermoplastic Pressure Piping; Code of Federal Regulations, Title 49, Transportation Part 192; AGA Plastic Pipe Manual and/or The Guidance Manual for Operators of Small Gas Systems by the U.S. Department of Transportation.